

OptiPEAK TDL600

Moisture in Natural Gas Analyzer

The next generation TDLAS Analyzer for automatic online measurement of moisture in variable compositions of natural gas and biomethane. The OptiPEAK TDL600 Tuneable Diode Laser Analyzer employs the latest techniques in laser absorption spectroscopy and signal processing power to offer a robust high performance analyzer, designed specifically for the measurement of moisture in natural gas. This non-contact technology requires minimal maintenance, even in demanding applications such as changing methane concentrations or sour gas. The analyzer is fully hazardous area certified and delivers class-leading measurement performance, stability and detection sensitivity.



Highlights

- D-MET system: Factory ready for varying gas compositions e.g. after stream blending, in shale gas or biomethane
- Operating range down to 1 ppmv
- Sour gas compatible
- Simple installation and setup
- Lowest maintenance
- Class I, Division 1 certified for hazardous areas
- Integrated sample handling
- Proven Michell Instruments quality: 40 years of expertise in moisture measurement built into the design

Applications

- Natural gas glycol dehydration
- Natural gas transmission monitoring
- Custody transfer
- Natural gas storage
- Offshore export pipeline natural gas
- LNG receiving / re-gasification plants
- Vaporized NGL
- Biomethane

40 Years of Experience with Moisture and Hydrocarbon Dew-Point Measurement in Natural Gas

The control of moisture and hydrocarbon dew point is critical for the operational safety and efficiency of the plant equipment in upstream through to downstream processes.

We at Michell Instruments have been developing expert moisture sensing instruments and systems for 40 years. Over this time, we have gained extensive knowledge of applications in natural gas with thousands of analyzer installations in sites across the globe. Today Michell Instruments offers customers in the oil and gas industry a suite of complementary moisture and hydrocarbon dew-point analyzers and systems.

The OptiPEAK Difference

Performance

- High accuracy with lower detection limit of <1 ppmv
- Range of 1 to 1000 ppmv

The OptiPEAK TDL600's lower detection limit (LDL) of less than 1 ppmv makes the instrument a class leader in single path TDLAS moisture analyzers currently commercially available.

The maintenance-free, simple dual pass cell offers reliable measurement results throughout its range. It combines sensitivity and robustness without the high top-end range limit which could make the analyzer likely to saturate quickly at higher moisture levels. This is sometimes the case with comparable, costly and difficult to maintain multi-pass (Herriot) cells. With its accuracy of 1 ppmv the analyzer is future proof and comfortably exceeds the requirements of the main international natural gas quality harmonization guidelines in Europe and United States.

- D-MET — active gas composition compensation for multi-source dynamic gas streams: shale gas and biomethane ready

Natural gas stream compositions can vary. In some applications it is difficult to use an older generation TDL instrument which can only be tuned to one defined gas composition. Michell Instruments' next generation TDL hygrometers overcome this limit. The OptiPEAK TDL600 utilizes the innovative D-MET System, dynamic background gas compensation. For the user, this means that the moisture measurement is virtually independent of changes in the methane level. No further manual correction factors are required.

Reliability

- Signal drift reduction — built-in, continuous laser optimization

Tuneable diode lasers can drift. This inherent property of diode lasers can lead to reduction in sensitivity and drift in

measured readings. The OptiPEAK's built-in continuous laser optimization system ensures that the laser remains locked to the correct water absorption peak for the highest measurement integrity at all times.

- High-accuracy temperature control

For the optimal performance of any TDL hygrometer the temperature stability is of highest concern. The OptiPEAK series not only utilizes the highest quality laser with exceptional life span, but also has a sophisticated multi-stage control system to maintain the temperature of the laser to within tight limits.

Simplicity

- Human Machine Interface (HMI)

The TDL600 provides a highly intuitive, color, menu-driven interface, utilizing a capacitive touch pad. This allows operation and interrogation of the analyzer in the field with no need for a hot-works permit. Navigation is easy and there is no need for a stylus.

- Easy integration into existing control systems

The OptiPEAK TDL600 is equipped with 3 programmable 4–20 mA analog outputs and a digital output utilizing the widespread ModBus Protocol for easy connection to a SCADA or other user-defined data acquisition system.

- Integrated sampling system

The OptiPEAK series is supplied with a high quality, in-house designed, sample conditioning system that is optimized for the applications in natural gas as well as the high speed of response of the analyzer.

- Remote application software supplied as standard

Allows remote control and configuration of the analyzer to simplify operations on large, distributed locations.

Reduced cost of ownership

- Minimum installation and maintenance

With its integrated sampling system and small footprint, the OptiPEAK TDL600 can be easily retrofitted into existing plant infrastructure. Due to the inherent stability of the instrument, regular field calibration is not required under normal operating conditions. The analyzer will perform reliably for many years with just basic maintenance and housekeeping.

- Built-in self verification

The OptiPEAK TDL600's innovative self-verification and self-compensation system checks itself against calibration data on every update cycle, adjusting if necessary, without the need for an additional gas reference cell. This function is extremely useful after a system upset — there is no need for a lengthy setup procedure.



Sample Conditioning Systems

A well designed sampling system is key to achieving correct measurement and reliable long-term operation of any natural gas moisture analyzer. The sample conditioning system of the OptiPEAK TDL600 applies state-of-the-art filtration and multi-stage pressure reduction to present a clean, wholly gaseous phase representative sample for continuous analysis. Systems that disregard the requirements for adequate sample conditioning will fail to achieve the levels of accuracy promised in the analyzer data sheet and also may be very costly for the user in the longer term.

While the fast response speed of TDL based analyzers is an important advantage, it is also widely accepted that the quality of the sample conditioning system design and its finish determine the performance of the entire measuring system. This is particularly valid for measurement of trace water vapor in single or double digit ppm ranges where the adsorption and desorption of the water molecules from surfaces in the conditioning system has to be considered.

Michell Instruments have 40 years of experience with low moisture measurements in process applications. The OptiPEAK series' instruments are supplied with a high quality sample conditioning system that is optimized for applications in natural gas, as well as the high speed of response of the analyzer.



Our products are also backed up by global service and support. With locations on 6 continents and 56 countries, Michell Instruments offers an extensive network of factory trained application engineers ready to analyze your application and deliver the solution. This allows us to assure customer satisfaction throughout your products lifetime.

If you can't find a product to fit your application contact your local Michell Instruments office, or visit our website www.michell.com — we're here to help.



The Moisture Specialists:

We have the solution for your moisture sensing needs

With 5 proprietary moisture sensing technologies, Michell Instruments will tailor solutions to best fit the specifics of your application, as well as the project budget.

Relative Humidity Sensors:

Designed for a broad range of heavy industrial and process industries.

Ceramic Sensor Technology:

3rd generation of metal oxide for natural gas applications at high pressure (CNG) and economical, easy gas processing applications.

Chilled Mirror:

For precise reference measurements at the highest accuracy and NPL or NIST traceability.

Quartz Crystal Microbalance:

For fast, precise measurement at low ranges in changing backgrounds.

TDLAS:

For fast, precise and low maintenance measurement in natural gas from 1000 ppmv down to 1 ppmv.

Technical Specifications

Measurement technology	TDLAS
Measurement range	1 ppmv to 1000 ppmv
Accuracy	±1% of reading >100 ppmv ±1ppmv <100 ppmv
Repeatability	<1 ppmv (long term stability <0.1 ppmv/year)
Limit of detection	1 ppmv
Available units	ppmv, lb/MMSCF, (ISO18453 or IGT#8), mg/Nm ³ , dew point °C or °F
Response speed	Optical response 0.2s Display update 2 to 3s
Operating temperature range	-20 to +55°C (-4 to +131°F)
Electrical Specifications	
Supply voltage	110 V AC or 230 V AC 50/60Hz
Power requirements	
Indoor system:	80W
Outdoor system:	180W
Analog signals	
Input:	2 x 4–20 mA user configurable
Output:	3 x 4–20 mA, 3 alarms 250 V AC, 3A (volt-free contacts)
Digital communications	RS485 ModBus RTU
Data logging	Logs all process variables with a user selectable sample period in the range of 10s to 1 day

Local interface	4.3" color LCD with touch pad operation
Electrical connections	3 x M20 entries for cable glands
Calibration	
Factory method	3-point, traceable to NPL and NIST
Recommended calibration	None required, dependant on user or quality system requirements
Physical Specifications	
Sample flow rate	1 NI/min cell sample, 1 to 5 NI/min sample filter by-pass
Inlet pressure	Maximum 2000 psig (138 barg)
Outlet pressure	Cell vent 10 to 20 psia (0.7 to 1.4 bara) Filter by-pass maximum 43.5 psig (3 barg)
Enclosure type/ packaging	Aluminum alloy, explosion proof, polyester coated, IP66, NEMA 4
Gas connections	1/4" NPT (F)
Weight	88lbs (40kg) (without sampling system)
Sample system enclosure	304L or 316L stainless steel
Hazardous area certification	
ATEX:	II 2 G Ex d ib op is IIC T5 Gb Ta -20°C to +60°C
IECEX:	2G Ex d ib op is IIC T5 Gb Ta -20°C to +60°C
cMETus:	Class I, Division 1, Groups A, B, C, D, T5, Tamb -20°C to +60°C, IP66
TC TR Ex:	1 Ex d ib op is IIC T5 Gb

Dimensions

Indoor/Outdoor Version

OptiPEAK TDL600 indoor system supplied with sampling system panel-mounted only.

Outdoor system is panel-mounted housed in an enclosure;

Both versions certified by cMETus Labs for installation in NEC Class I Division 1 hazardous area locations.

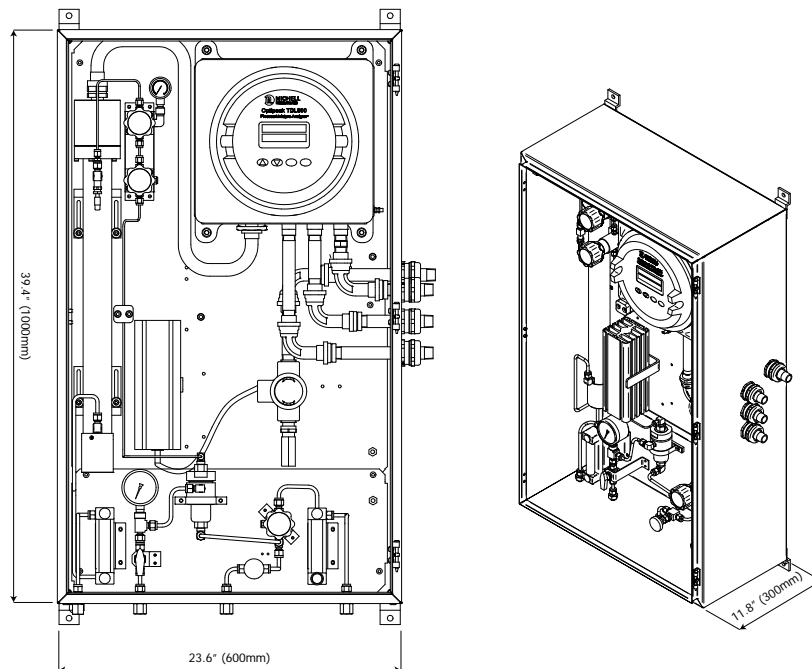

Michell Instruments, Inc 319 Newburyport Turnpike, Suite 207, Rowley, MA 01969
Tel: 978 484 0005, Fax: 978 843 7669, Email: us.info@michell.com, Web: www.michell.com/us

Michell Instruments adopts a continuous development programme which sometimes necessitates specification changes without notice.
Issue no: OptiPEAK TDL600_97470_V2.1_US_0315



HAUSNET S.R.L.

Tel Argentina: (+54-11) 5219-2211
Tel Chile: (+56-2) 2897-3999
E-Mail: hausnet@hausnet.com.ar
Web: www.hausnet.com.ar